



Renewable Water Resources
Greenville, South Carolina

CONTRACT DOCUMENTS
Reedy River Basin Sewer Tunnel

ADDENDUM III - CONTRACT REVISIONS



Prepared by

Black & Veatch Corporation
Greenville, South Carolina



BLACK & VEATCH

B&V Project No. 192263

September 22, 2017

Renewable Water Resources

CONTRACT DOCUMENTS Reedy River Basin Sewer Tunnel

ADDENDUM III - CONTRACT REVISIONS

- A. SCOPE. This is an attachment to the Addendum III Reedy River Basin Sewer Tunnel RFB and consists of pages ADIII-1 through ADIII-5. This Addendum III covers the following additions and changes to the Project Manual and Drawings and also consists of the following attachments:
- Specification Section 00400 – BID FORM (9 pages) (Pages ADIII-6 through ADIII-14).
 - Revised Drawings Y02, Y03, Y04, Y06, C11, C13, C14, C15, C17, C20, S02, S06, S07, S13.
- B. PROJECT MANUAL.
1. Section 00020 – INVITATION TO BID.

Page 1. Paragraph 1. Delete “October 5, 2017” and replace with “October 17, 2017.”

Page 3. Paragraph 4. To clarify proper corporate names, please delete the bulleted list below this Paragraph in its entirety and replace with the following list. There are no changes to the list of prequalified bidders.

 - “Guy F. Atkinson Construction, LLC
 - Jay Dee Contractors, Inc.
 - McNally Tunneling Corporation
 - Michels Corporation
 - SAK Construction, LLC
 - Super Excavators/CMCRA, A Joint Venture
 - Traylor/Bradshaw, Joint Venture
 - Triad McNally Joint Venture”

2. Section 00100 – INSTRUCTION TO BIDDERS.

Page 10. Paragraph 12.04.

Delete bullet point “h” that begins with “Full description of tunnel excavation methods for all...” in its entirety.

Delete bullet point “i” that begins with “Full description of tunnel excavation methods, support...” in its entirety.

3. Section 00400 – BID FORM.

Delete this Section in its entirety and insert the attached revised Section 00400 – BID FORM.

4. Section 00800 – SUPPLEMENTARY CONDITIONS.

Page 16. Article SC-6.03. Contractors Insurance. Add the following to the end of the list of additional insureds:

“Windsor/Aughtry Company, Inc. (Tax Map No. 0058000300800) 301 River Street, Greenville, SC 29601

District West Apartments (Tax Map No. 0057000200500) 101 Reedy View Drive, Greenville, SC 29601

McBee Station Greenville, LLC (Tax Map No. 0062000200203) 27 Station Court, Greenville, SC 29601”

Page 23. Delete “Add the following paragraphs after Paragraph 6.09C.” and replace with “Add the following paragraphs after Paragraph 7.10.C.”

Page 26. Paragraph F. Work in Confined Spaces. Delete Paragraph 7.10.F. that begins “Work in Confined Spaces” in its entirety.

5. Section 01025 – PROGRESS PAYMENT PROCEDURES.

Page 4. Replace Paragraph 4.11. Drop Shaft Welded Wire Fabric., with the following:

“4.11. Drop Shaft Welded Wire Fabric. Payment for the Drop Shaft welded wire fabric shall be made on the basis of the square foot unit price established in the Bid. Measurement for payment for pattern rock dowels required to attach the welded wire fabric will be made under the

appropriate Bid item. The unit price for welded wire fabric includes all other costs associated with furnishing and installing this rock support.”

Page 5. Replace Paragraph 4.19. Access Shaft Welded Wire Fabric, with the following:

“4.19. Access Shaft Welded Wire Fabric. Payment for the Access Shaft welded wire fabric shall be made on the basis of the square foot unit price established in the Bid. Measurement for payment for pattern rock dowels required to attach the welded wire fabric will be made under the appropriate Bid item. The unit price for welded wire fabric includes all other costs associated with furnishing and installing this rock support.”

6. Section 02050 – DEMOLITION.

Page 2. Paragraph 3-1.01. Structure Demolition. In the first sub-paragraph, delete the sentence, “See Paragraph 3-2.02, brick façade shall be salvaged.”

7. Section 02120 – GEOTECHNICAL INSTRUMENTATION.

Page 1. Paragraph 1-2. RELATED SECTIONS. Delete the last sentence of this Section that begins with “Geotechnical instrumentation...” in its entirety.

8. Section 04200 – MASONRY.

Page 3. Paragraph 1-6. BRICK ALLOWANCE. In the first sentence, delete “District West Apartments” and replace with “Sarkis Studio”.

C. PROJECT DRAWINGS.

1. Drawing Y02 – Demolition Plan, Drop Shaft and Upstream Connections. Delete Drawing Y02 in its entirety and replace with the attached Drawing Y02 to reflect revisions to the alignment of the 42-inch piping at Hudson Street.
2. Drawing Y03 – Site Plan, Access Shaft and Downstream Connections. Delete Drawing Y03 in its entirety and replace with the attached Drawing Y03 to reflect grade lines adjacent to the Access Shaft Site.
3. Drawing Y04 – Site Plan, Drop Shaft and Upstream Connections. Delete Drawing Y04 in its entirety and replace with the attached Drawing Y04 to reflect revisions to the alignment of the 42-inch piping at Hudson Street.

4. Drawing Y06 – Restoration Plan, Drop Shaft and Upstream Connections. Delete Drawing Y06 in its entirety and replace with the attached Drawing Y06 to reflect revisions to the alignment of the 42-inch piping at Hudson Street.
5. Drawing C11 – Plan and Profile, Drop Shaft and Upstream Connections. Delete Drawing C11 in its entirety and replace with the attached Drawing C11 to reflect revisions to the alignment of the 42-inch piping at Hudson Street.
6. Drawing C13 – MH 590A - Junction Box, Plan and Sections. Delete Drawing C13 in its entirety and replace with the attached Drawing C13 to reflect revisions to the Junction Box base slab.
7. Drawing C14 – MH 400C-219B - Diversion and Screening Structure, Plan and Sections. Delete Drawing C14 in its entirety and replace with the attached Drawing C14 to reflect revisions to the Diversion Structure base slab.
8. Drawing C15 – MH 400C-219B - Diversion and Screening Structure, Sections and Details. Delete Drawing C15 in its entirety and replace with the attached Drawing C15 to reflect revisions to the Diversion Structure base slab.
9. Drawing C17 – Miscellaneous Details (2 of 4). Delete Drawing C17 in its entirety and replace with the attached Drawing C17 to reflect revisions to the Doghouse Vault base slab.
10. Drawing C19 – Miscellaneous Details (4 of 4). Detail A/C19. Rename callout bubble for RIP RAP from “A/-” to “D/-”. Rename callout for STONE RIP-RAP DETAIL from “A” to “D”.

Add the following detail as new “Detail C”:

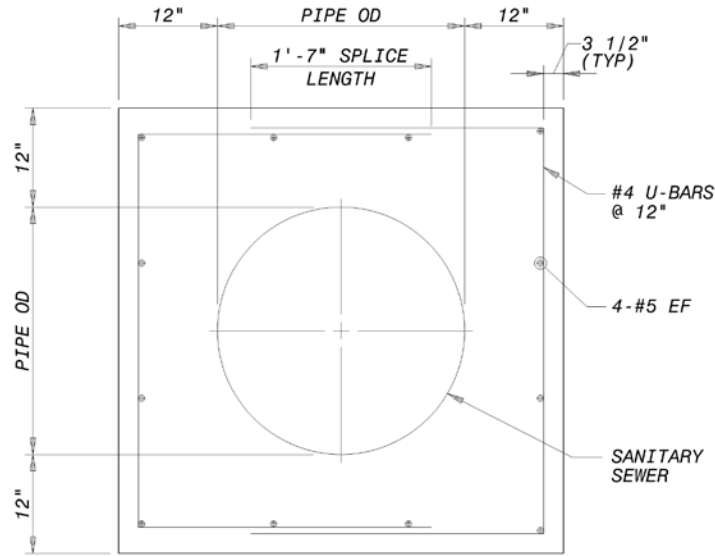

NOTES:

1. USE 3000 PSI CONCRETE.
2. CONCRETE ENCASEMENT SHALL EXTEND A MIN OF 10 FEET EACH SIDE OF TRANSMISSION MAIN OR TO NEAREST MANHOLE. BEGIN AND END ENCASEMENT AT SEWER JOINT.

CONCRETE ENCASEMENT DETAIL C
 NO SCALE

11. Drawing C20 – Diversion and Screening Structure - 3D Views and Renderings. Delete Drawing C20 in its entirety and replace with the attached Drawing C20 to reflect revisions to the Diversion Structure base slab.
12. Drawing S02 – Shaft Design, Access Shaft Connection (1 of 2). Delete Drawing S02 in its entirety and replace with the attached Drawing S02 to reflect revisions to the Access Shaft base slab.
13. Drawing S06 – MH 590A - Junction Box, Plans and Sections. Delete Drawing S06 in its entirety and replace with the attached Drawing S06 to reflect revisions to the Junction Box base slab.
14. Drawing S13 – Doghouse Vault Manhole Plans and Sections. Delete Drawing S13 in its entirety and replace with the attached Drawing S13 to reflect revisions to the Doghouse Vault base slab.

D. ACKNOWLEDGMENT BY BIDDER. Each Bidder is required to acknowledge receipt of this Addendum No. 3 in the space provided in the Bid.

Section 00400

BID FORM

PROJECT IDENTIFICATION:

Reedy River Basin Sewer Tunnel

ARTICLE 1 – BID RECIPIENT

1.01. This Bid is submitted to:

Renewable Water Resources
561 Mauldin Road
Greenville, South Carolina 29607

1.02 The undersigned Bidder proposes and agrees, if this Bid is accepted, to enter into an agreement with Owner in the form included in the Bidding Documents to perform all Work as specified or indicated in the Bidding Documents for the prices and within the times indicated in this Bid and in accordance with the other terms and conditions of the Bidding Documents.

ARTICLE 2 – BIDDER’S ACKNOWLEDGEMENTS

2.01. Bidder accepts all of the terms and conditions of the Instructions to Bidders, including without limitation those dealing with the disposition of Bid security. This Bid will remain subject to acceptance for 90 days after the day of Bid opening, or for such longer period of time that Bidder may agree to in writing upon request of Owner. Bidder will sign and submit the Agreement with the bonds and other documents required by the Bidding Documents to Owner within 15 days after the date of Owner's Notice of Award.

ARTICLE 3 – BIDDER’S REPRESENTATIONS

3.01. In submitting this Bid, Bidder represents that:

A. Bidder has examined and carefully studied the Bidding Documents, and any data and reference items identified in the Bidding Documents, and hereby acknowledges receipt of the following Addenda:

No. _____ Dated _____

No. _____ Dated _____
No. _____ Dated _____
No. _____ Dated _____
No. _____ Dated _____

- B. Bidder has visited the Site, conducted a thorough, alert visual examination of the Site and adjacent areas, and become familiar with and is satisfied as to the general, local, and Site conditions that may affect cost, progress, and performance of the Work.
- C. Bidder is familiar with and satisfied itself as to all Laws and Regulations that may affect cost, progress, and performance of the Work.
- D. Bidder is aware that the Geotechnical Baseline Report, Volume 2 of 3, and the Geotechnical Data Report, Volume 3 of 3, are Contract Documents. The Geotechnical Baseline Report constitutes a geotechnical baseline definition of subsurface conditions and behaviors during construction which are expected to be encountered on the tunnels and shafts portion of this Project.
- E. Bidder has carefully studied all: (1) reports of explorations and tests of subsurface conditions at or adjacent to the Site and all drawings of physical conditions relating to existing surface or subsurface structures at the Site that have been identified in Section 00800 - Supplementary Conditions, especially with respect to Technical Data in such reports and drawings, and (2) reports and drawings relating to Hazardous Environmental Conditions, if any, at or adjacent to the Site that have been identified in Section 00800 - Supplementary Conditions, especially with respect to Technical Data in such reports and drawings.
- F. Bidder has considered the information known to Bidder itself; information commonly known to contractors doing business in the locality of the Site; information and observations obtained from visits to the Site; the Bidding Documents; and any Site-related reports and drawings identified in the Bidding Documents, with respect to the effect of such information, observations, and documents on (1) the cost, progress, and performance of the Work; (2) the means, methods, techniques, sequences, and procedures of construction to be employed by Bidder; and (3) Bidder's safety precautions and programs.
- G. Bidder agrees, based on the information and observations referred to in the preceding paragraph, that no further examinations, investigations, explorations, tests, studies, or data are necessary for the determination of

this Bid or performance of the Work at the price bid and within the times required, and in accordance with the other terms and conditions of the Bidding Documents.

- H. Bidder is aware of the general nature of work to be performed by Owner and others at the Site that relates to the Work as indicated in the Bidding Documents.
- I. Bidder has given Engineer written notice of all conflicts, errors, ambiguities, or discrepancies that Bidder has discovered in the Bidding Documents, and confirms that the written resolution thereof by Engineer is acceptable to Bidder.
- J. The Bidding Documents are generally sufficient to indicate and convey understanding of all terms and conditions for the performance and furnishing of the Work.
- K. The submission of this Bid constitutes an incontrovertible representation by Bidder that Bidder has complied with every requirement of this Article, and that without exception the Bid and all prices in the Bid are premised upon performing and furnishing the Work required by the Bidding Documents.

ARTICLE 4 – BIDDER’S CERTIFICATION

4.01. Bidder certifies that:

- A. This Bid is genuine and not made in the interest of or on behalf of any undisclosed individual or entity and is not submitted in conformity with any collusive agreement or rules of any group, association, organization, or corporation;
- B. Bidder has not directly or indirectly induced or solicited any other Bidder to submit a false or sham Bid;
- C. Bidder has not solicited or induced any individual or entity to refrain from bidding; and
- D. Bidder has not engaged in corrupt, fraudulent, collusive, or coercive practices in competing for the Contract. For the purposes of this Paragraph 4.01.D:
 - 1. “corrupt practice” means the offering, giving, receiving, or soliciting of anything of value likely to influence the action of a public official in the bidding process;

2. “fraudulent practice” means an intentional misrepresentation of facts made (a) to influence the bidding process to the detriment of Owner, (b) to establish bid prices at artificial non-competitive levels, or (c) to deprive Owner of the benefits of free and open competition;
3. “collusive practice” means a scheme or arrangement between two or more Bidders, with or without the knowledge of Owner, a purpose of which is to establish bid prices at artificial, non-competitive levels; and
4. “coercive practice” means harming or threatening to harm, directly or indirectly, persons or their property to influence their participation in the bidding process or affect the execution of the Contract.

E. Bidder has attended the Pre-Bid conference.

F. The Bidder understands that Renewable Water Resources reserves the right to reject any and all Bids and to waive informalities in the bidding.

ARTICLE 5 – BASIS OF BID

5.01. Bidder will complete the unit price Work for the unit prices noted below, computed in accordance with Paragraph 13.03 of Section 00700 – Standard General Conditions of the Construction Contract. Bidder acknowledges that estimated quantities are not guaranteed and are solely for the purpose of comparison of Bids, and that final payment for all Unit Price Bid items will be based on actual quantities provided, determined as provided in the Contract Documents.

The Bidder agrees to perform all work described in the Contract Documents for the following Lump Sum and Unit Prices including all labor, materials, equipment sales, and other applicable taxes and fees.

Item	Description	Est. Quantity	Unit	Unit Cost	Total Cost
<u>Allowances</u>					
1	Disputes Review Board Allowance	1	LS	\$120,000	_____
2	Owner's Contingency Allowance	1	LS	\$2,000,000	_____
3	Landscaping Allowance	1	LS	\$150,000	_____
3a	Contaminated Material Disposal Allowance	1	LS	\$100,000	_____
4	Mobilization (4% of Base Bid)	1	LS	_____	_____
5	Tunnel Boring Machine Mobilization (4% of Base Bid)	1	LS	_____	_____
ALLOWANCES (Sum of Items 1-5)					_____
<u>Shafts and Tunnel</u>					
6	Geotechnical Instrumentation	1	LS	_____	_____
7	Drop Shaft Site Demolition and Cleanup				
7a	WED Property/Chorbadjian	1	LS	_____	_____
7b	City of Greenville Stormwater Annex	1	LS	_____	_____
8	Drop Shaft Overburden Excavation and Initial Support	18	VF	_____	_____
9	Drop Shaft Excavation Rock	90	VF	_____	_____
10	Drop Shaft Pattern Rock Doweling	90	VF	_____	_____
11	Drop Shaft Welded Wire Fabric	6800	SF	_____	_____
12	Drop Shaft Concrete Lining	1	LS	_____	_____
13	Drop Shaft Corrosion Protective Lining	1	LS	_____	_____
14	IPEX Vortex & Installation	1	LS	_____	_____
15	Access Shaft Site Preparation	1	LS	_____	_____
16	Access Shaft Overburden Excavation and Initial Support	17	VF	_____	_____
17	Access Shaft Excavation Rock	20	VF	_____	_____
18	Access Shaft Pattern Rock Doweling	20	VF	_____	_____
19	Access Shaft Welded Wire Fabric	600	SF	_____	_____
20	Access Shaft Concrete Lining	1	LS	_____	_____
21	Access Shaft Corrosion Protective Lining	1	LS	_____	_____
22	Tunnel Excavation and Initial Support Class I	4641	LF	_____	_____
23	Tunnel Excavation and Initial Support Class II	1309	LF	_____	_____
24	Tunnel Spot Rock Doweling	120	EA	_____	_____

25	Tunnel Welded Wire Fabric	3100	SF	_____	_____
26	Tunnel Steel Channel Support	300	LF	_____	_____
27	Tunnel Carrier Pipe Installation	5950	LF	_____	_____
28	Tunnel Grouting	5950	LF	_____	_____
<u>Near Surface Connections and Diversions</u>					
29	Diversion/Screening Structure	1	LS	_____	_____
30	Junction Box (MH 400A-590A)	1	LS	_____	_____
31	Cast-in-Place Doghouse Manholes	2	EA	_____	_____
32	Pre-Cast Manholes and Bases				
32a	10-foot Diameter Manhole	1	EA	_____	_____
32b	6-foot Diameter Manhole	3	EA	_____	_____
32c	5-foot Diameter Manhole	3	EA	_____	_____
33	Connection to Existing Manhole	1	LS	_____	_____
34	Not Used.				
35	42-inch Sewer Installation	1150	LF	_____	_____
36	60-inch Sewer Installation	345	LF	_____	_____
37	Richland Creek Crossing	1	LS	_____	_____
38	Rock Excavation for Sewer Installation	2000	CY	_____	_____
39	Undercutting Unsuitable Material	700	CY	_____	_____
40	Select Fill to Replace Undercutting Unsuitable Material	350	CY	_____	_____
41	Crushed Rock to Replace Undercutting Unsuitable Material	350	CY	_____	_____
<u>Other Work</u>					
42	Odor Control System	1	LS	_____	_____
43	Odor Control Screening Area	1	LS	_____	_____
44	Drop Shaft Site Restoration	1	LS	_____	_____
45	Riley Street Realignment and Extension	1550	SY	_____	_____
46	Access Shaft Site Restoration	1	LS	_____	_____
47	Mill and Resurface Roadways	13000	SY	_____	_____
48	Storm Drain and New Catch Basins	1	LS	_____	_____
BASE BID (Sum Items 6-48)					
TOTAL BASE BID (Sum of all ALLOWANCES and BASE BID)				\$ _____	

Bid Alternative No. 1 – Nighttime Work					
A1a	Noise Wall (<i>Additive</i>)	1	LS	_____	_____
A1b	Nighttime Work Cost Savings <i>[Deduct]</i>	1	LS	(_____)	(_____)
SUBTOTAL: Sum A1 Items					_____

ARTICLE 6 – TIME OF COMPLETION

6.01. Bidder agrees that the Work will be substantially complete within **814** calendar days after the date when the Contract Times commence to run as provided in Paragraph 4.01 of the General Conditions, and will be completed and ready for final payment in accordance with Paragraph 15.06 of Section 00700 – Standard General Conditions of the Construction Contract within **844** calendar days after the date when the Contract Times commence to run.

Greenville Zoo Milestone: Completion of Access Shaft, Downstream Connections, Downstream Site Restoration, and full return of Parking Lot back to the Greenville Zoo	within 760 calendar days from Notice to Proceed
Substantial Completion	within 814 calendar days from Notice to Proceed
Final Completion	within 844 calendar days from Notice to Proceed

6.02. Bidder accepts the provisions of the Agreement as to liquidated damages in the event of failure to complete the Work within the times specified in the table above.

ARTICLE 7 – ATTACHMENTS TO THIS BID

7.01. Bidder hereby acknowledges that the following completed documents are included with its bid [Bidder to acknowledge by placing a checkmark next to each item]:

- 00400 Bid Form _____
- 00411 Notice and Claim Procedures Acknowledgement Form _____
- 00412 South Carolina Illegal Immigration Reform Act _____
- 00413 Statement of Compliance with SC Code 12-8-550 _____
- 00414 Compliance with State Revolving Fund Requirements _____
- 00430 Bid Bond _____
- 00440 List of Subcontractors _____
- 00450 Equipment Questionnaire _____

00480 Non-Collusion Affidavit _____
00482 Non-Segregated Facilities Affidavit _____

-- Work Plan. General description of means and methods, as well as a general description of the following:

- a. Excavation and initial support for each access/retrieval shaft and all tunnel drives. _____
- b. Groundwater removal for access/retrieval shafts and all tunnel drives. _____
- c. Muck handling for access/retrieval shafts and all tunnel drives. _____
- d. Ventilation for access/retrieval shafts and all tunnel drives. _____
- e. Final lining methods for each access/retrieval shaft. _____
- f. Carrier pipe and grouting methods for all tunnel drives. _____
- g. General assembly drawings and technical data for the tunnel boring machine(s)/mechanized tunnel machine(s) as outlined in the technical specifications. _____

00800
App A State Revolving Fund Forms

SCDHEC Form 3590 – State of South Carolina State Revolving Fund (SRF) Program – Certification Regarding Debarment, Suspension, and Other Responsibility Matters _____

ARTICLE 8 – DEFINED TERMS

8.01. The terms used in this Bid have the meanings stated in Section 00100 - Instructions to Bidders, Section 00700 - Standard General Conditions of the Construction Contract, and Section 00800 - Supplementary Conditions.

ARTICLE 9 – BID SUBMITTAL

BIDDER: _____
(Correct name of bidding entity)

By: _____
(Signature)
(If Bidder is a corporation, a limited liability company, a partnership, or a joint venture, attach evidence of authority to sign.)

(Printed name)

Attest: _____
(Signature)

(Printed name)

(Title)

Submittal Date: _____

Address for giving notices:

Telephone Number: (_____) _____

Fax Number: (_____) _____

Contact Name and e-mail address: _____

South Carolina General Contractor's License Number: _____

License Expiration Date : _____

End of Section